

TD Welcome

This is my eighth year actively involved in the tournament and likely my last. Whether you've been here all eight years, or this is your first, of if you're used to 70 degree weather in January or minus 20, thank you for making NYF part of your ultimate life. As my tenure comes to a close, I would like you to do me a favor. I would like you to look closely at the name of the tournament. What do you see? Or, rather, not see? The answer is an "S". It's New YEAR Fest. This year, last year, all 27 years. Just wanted to clear that up.

Keith Aspinall

NYF 2009 RULES

Except where otherwise stated, NYF will run under the UPA's 11th Edition rules.

- All games are to 13, win by 2, cap at 15.
- Women's A and Open A finals are first to 15.
- 15-yard brick on out-of-bounds pulls.
- Up to two substitutions per team, per timeout.
- Mirror image, no half. Finals will have a mirror halftime.
- One timeout per half, plus a floater (3 per game).
- The soft cap horn will sound at 75 minutes. Teams with timeouts available can use no more than 1 during soft cap. At the completion of the point in progress when the soft cap horn sounds, add two points to the highest current score, and that is the new point cap for the game. (A point is considered to be in progress as soon as the preceding point has ended.) **Win-by-two is no longer required**, but any team that reaches 13 or more by a margin of two or more will be the winner of the game.
- Games will be hard-capped 10 minutes before the start of the next round. At the completion of the point in progress when the hard-cap horn sounds, the team in the lead is the winner. If the game is tied after the completion of that point, one more point is played to determine the winner. No timeouts (except injury timeouts) may be called once the hard-cap horn has sounded.
- Seeding for playoffs will be based on won/lost record during pool play. Tiebreakers will be applied in the following order: point differential in games between tied teams; total point differential; disc flip.

PLAYER INFORMATION

- 1) Games start on time. Be ready to play!
- 2) There is no tournament beer permit. If you have beer, be discreet and take empty cans with you.
- 3) There is a police substation adjacent to TSC
- 4) **NO GLASS ON ANY FIELD, EVER.** Please buy cans, or use plastic cups (available at Frisbee Central).
- 5) The party is age 18 and up.
- 6) **ALL DOGS MUST BE ON A LEASH.**
- 7) **Starbucks** is at 1620 W Elliot –west of Priest.
- 8) If you have a good time, let us know! **SOTG!!**

RECYCLE!!!

Large blue recycling dumpsters will be near each field. Please help out and be aware.

No trash in the recycling dumpsters.

What **CAN** go in the blue bins:
Plastic Water Jugs (no. 1, 2, or 6)
Paper and Cardboard
Cans & Glass

What **CANNOT** go in the bins:
Food
Fabric (old socks, tape)
Napkins, Paper Towels, Kleenex
Plastic Bags

Volunteers make NYF happen!!

Thanks to Jack Smith for coordinating the party, Jim Tolar, Greg Kendall, Vince Noe, Eric & Katherine Nabity, Joanne Aspinall, Stan Marks, Craig Suiter, Jim Moore, Tim Streit, and everyone who just lends a hand.

Women's Division

Diamond Pool Emerald Pool

- Suck n Blow - So Cal
1. Hella Bella - Wisconsin Reunion
- Con Gusto - Tucson
2. Lady Liquor - Colorado
- Kali Alum
3. Superfriends - Tufts Alum +
- Sac-It - Sacramento
4. Tomb - Notre Dame Alum
- Jines in the Pines - NAU
5. PHXation - Phx
- Caliente - ASU
6. Bombshells - UNM

Open Division

Black Pool Purple Pool Yellow Pool White Pool Red Pool

- Zippo - Colorado
1. Papal Age - Notre Dame Alum
- Big Sweet Onion
Co - Whitman Reunion
2. Le Tigre - Southwest Masters
- San Diego
3. Feel the Ridge - ASU Alum
- Sweet Roll - Albuquerque
4. Diablos - ASU
- Pass Interference #26 - Philadelphia
5. Pass Interference #26 - Philadelphia
- Chump Alums - Washington U Alum
- Freaks from the Peaks - Flagstaff Reunion
1. Freaks from the Peaks - Flagstaff Reunion
- Minus 20 - Calgary
2. Minus 20 - Calgary
- Monsoon - Tucson
3. Monsoon - Tucson
- Sprawl Y - Phx
4. Sprawl Y - Phx
- El Ponderoso - NAU
5. El Ponderoso - NAU

4th round in Pools P & Y are crossovers based on pool finish

| Field 7 | Field 8 | Field 14 | Field 13 | Field 12 | Round | Field 11 | Field 5 | Field 6 | Field 3 | Field 4 | Field 1 | Field 2 | Field 9 | Field 10 | Field 15 | Field 16 |
|---------|---------|----------|----------|----------|-------|----------|---------|---------|---------|---------|---------|---------|---------|----------|----------|----------|
| D1/D5 | D3/D4 | E3/E4 | E2/E6 | E1/E5 | 10:00 | D2/D6 | B4/B6 | B3/B5 | P1/P3 | P2/P4 | Y1/Y3 | Y2/Y4 | W1/W5 | W2/W4 | R1/R5 | R2/R4 |
| D1/D3 | D4/D5 | E3/E5 | E4/E6 | E1/E2 | 11:45 | B2/B3 | B1/B4 | B5/B6 | P1/P4 | P2/P3 | Y1/Y4 | Y2/Y3 | W1/W4 | W3/W5 | R1/R4 | R3/R5 |
| D1/D2 | D3/D5 | D4/D6 | E2/E4 | E1/E3 | 1:30 | B2/B4 | B1/B5 | B3/B6 | P1/P2 | P3/P4 | Y1/Y2 | Y3/Y4 | W1/W3 | W2/W5 | R1/R3 | R2/R5 |
| D1/D6 | D2/D3 | E4/E5 | E2/E3 | E1/E6 | 3:15 | B2/B5 | B1/B6 | B3/B4 | P1/Y2* | P3/Y3* | Y1/P2* | Y4/P4* | W1/W2 | W3/W4 | R1/R2 | R3/R4 |
| D5/D6 | D2/D4 | E5/E6 | | | 5:00 | | | | | B1/B2 | | | W2/W3 | W4/W5 | R2/R3 | R4/R5 |

Women Sunday 9:30 round

| Field 1 | Field 2 | Field 3 | Field 4 | Field 5 | Field 6 |
|---------|---------|---------|---------|---------|---------|
| D2/D5 | E2/E5 | E1/E4 | D1/D4 | D3/D6 | E3/E6 |

Sunday Championship Brackets

Open A Sunday Bracket

1:00 11:15 1:00 2:45

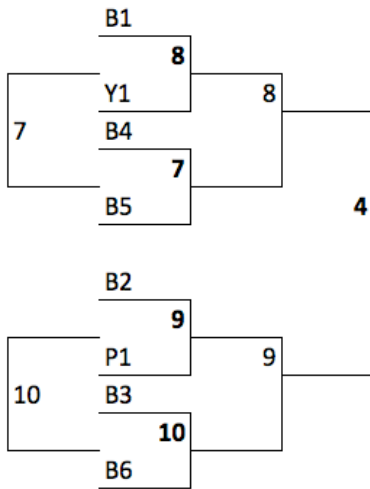

Open B Sunday Bracket

11:15 9:30 11:15 1:00

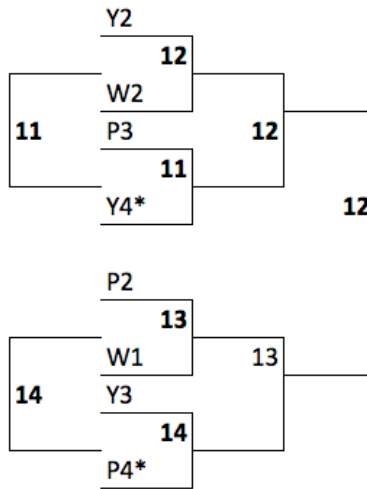

Open C Sunday Bracket

1:00 9:30 11:15 1:00

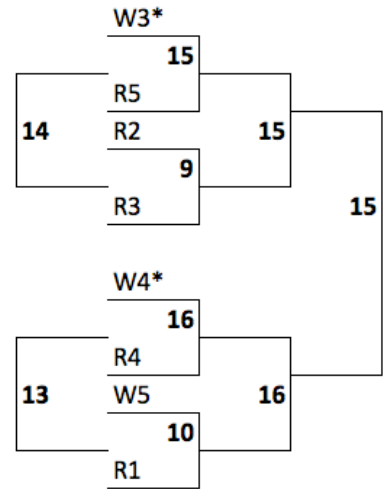

* Y4 and/or P4 may move down to C bracket based on Saturday results

Women's Sunday Brackets

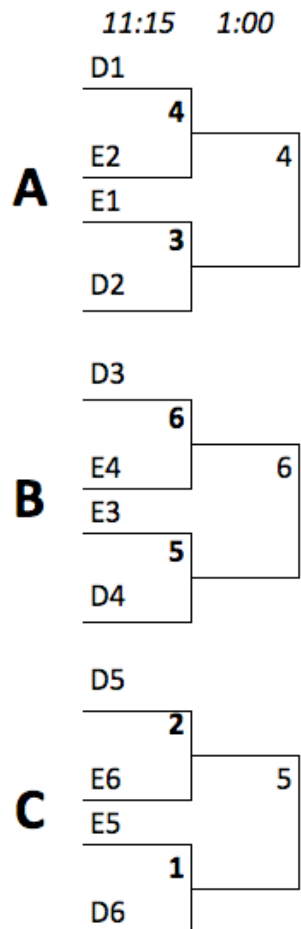

TEMPE SPORTS COMPLEX

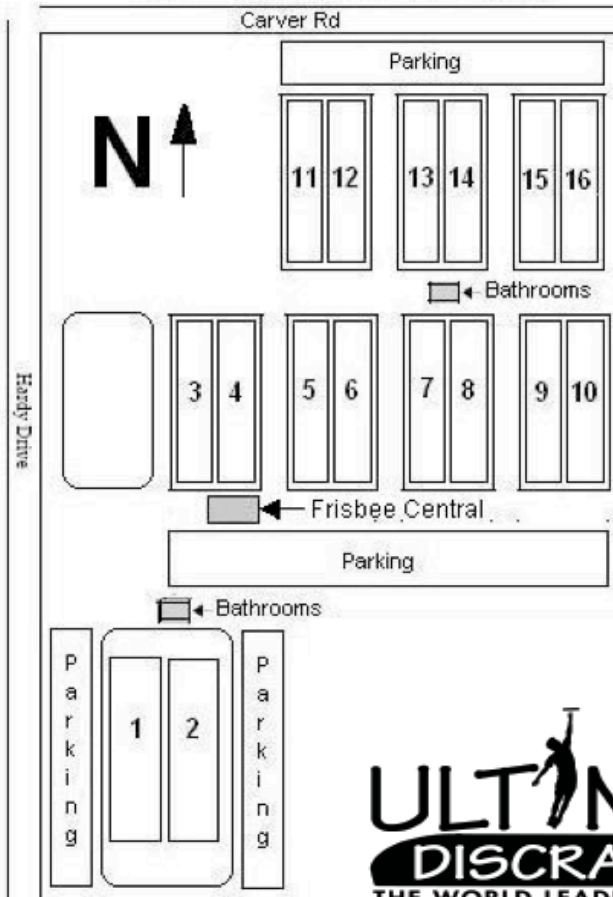

Good luck to all the competitors.



Area Map

PARTY: Dos Gringos

- 8000 S Priest Ave, west side of Priest between Elliot and Warner
- Party starts at 9 pm and is 18 and up
- Beer and margaritas are covered. On your own for mixed drinks.
- Teams must turn in scorecard and 5 gallon jug for party tickets

Restaurants North of Tempe Sports Complex*:

- Southeast Corner of Elliot and Kyrene: Pho Vietnamese, Moe's Southwest Grill, AZ Bread Company,
- Elliot Rd between Kyrene & I-10: Baja Fresh, Red Robin, Olive Garden and a bunch of other places.
- Wildflower Bread Company – SW corner of McClintock and Guadalupe

Restaurants South of Tempe Sports Complex*

- Ray & 54th St: Z-Tejas Southwestern Grill, Jilly's Sports Grill, Pei Wei, Bucca di Beppo
- Nello's – 4710 E Warner (48th St and Warner)
- Picazzo's Gourmet Pizza & Salads – 440 W Warner (Kyrene)
- Teakwoods – 5965 W Ray (Ray and Kyrene)

Ray Rd is 1 mile south of Warner.